

Magic Rack II Assembly Procedures

MAGIC
RACK

RACKING UP SOLUTIONS

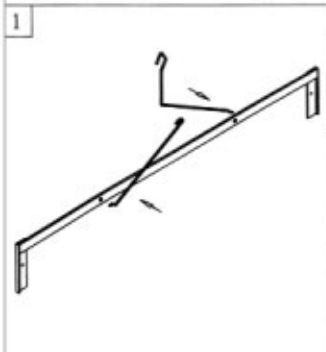

1
Insert Conveyor Hooks through the holes and on opposite sides of the Top Welded Assembly for stability of the Rack

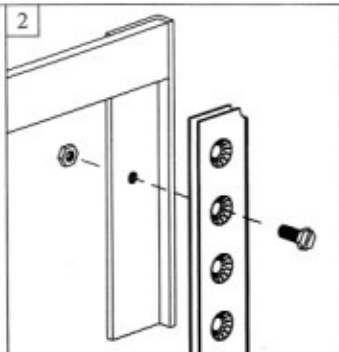

2
Bolt the Vertical Crossbar to the Top Welded Assembly. The offset hole alignment will force the Vertical Crossbar against the outside edge of the bracket

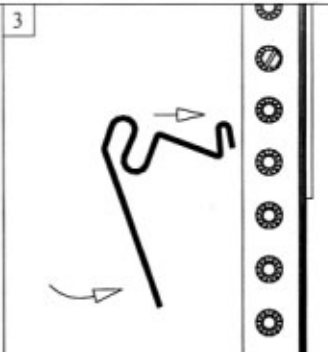

3
Insert the top portion of the Support Hook into the Vertical Crossbar and under an emboss. Next, "spring" the lower leg of the Support Hook up and into the Crossbar

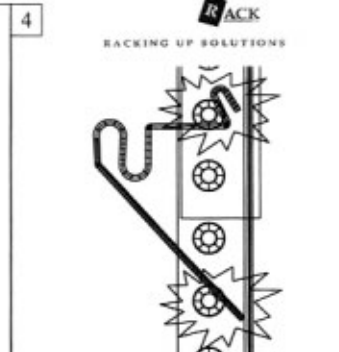

4
After properly installing the Support Hooks they will LOCK in place, not allowing the rack to come apart through your system!

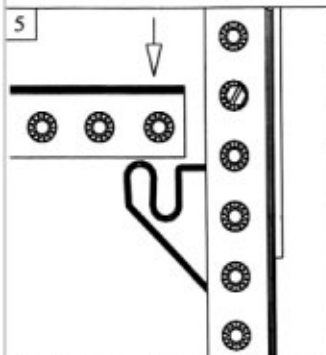

5
To install the Horizontal Crossbar simply "SNAP" the end emboss on each side onto the Support Hooks. To Remove: Brace the lower leg of the Support Hook and lift Crossbar

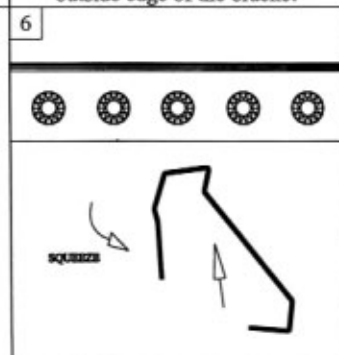

6
Installing our Parts Hook is easy! Simply press the "thumb squeeze" and insert between two embosses of the Crossbar

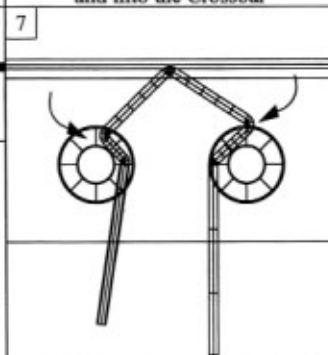

7
When installed the Hook is grounded inside the crossbar for optimum current flow and long lasting continuity

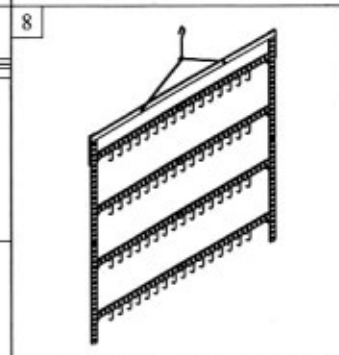

8
Magic Rack II complete and ready for your system!
If you have any questions please call (614) 492-8811 or check us out @ www.magicrack.com